

CHEMICAL ENGINEERING

May
1999

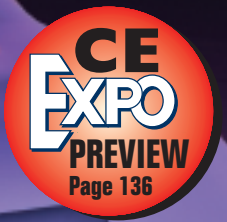

www.che.com

Make the Right Choice In Thermal Maintenance

Make the Right Choices In Thermal Maintenance

The bolt-on-jacketing option should not be overlooked

Henry Gaines, P.E.,
Controls Southeast, Inc.

In the planning and design of a chemical-process plant, engineers often do not give enough attention to maintaining acceptable process-fluid temperatures in piping, fittings, valves, pumps and other fluid-handling components. This is perhaps not surprising, as the required tracing or jacketing typically accounts for less than 1% of the capital cost of the plant. But improper choices or poor designs can cause a wide range of problems.

Freezeups can halt production, causing sizable costs in lost output. Conversely, hot spots in the fluid-handling system can degrade the product. And cross-contamination between a process fluid and a thermal fluid not only can interrupt production and adulterate the product, but also may ruin the jacketing system itself.

There are three main approaches to providing piping and other process equipment with thermal maintenance.* They are tracing, fabricated (welded) jacketing and bolt-on jacketing, each of which is described in more detail below.

The first two are relatively well known. The third, although not new, is less well known and is often overlooked. Accordingly, this article gives particular emphasis to bolt-on jacketing and its attractions.

*The phrase, "thermal maintenance," more accurately represents the true purpose of piping or component jacketing than does the traditional "process heating system." The main purpose of the system is to maintain consistent process temperature, not to raise the temperature. Even after a shutdown, it is our experience that temperature recovery in the pipe and piping components is rarely the bottleneck to resuming production.

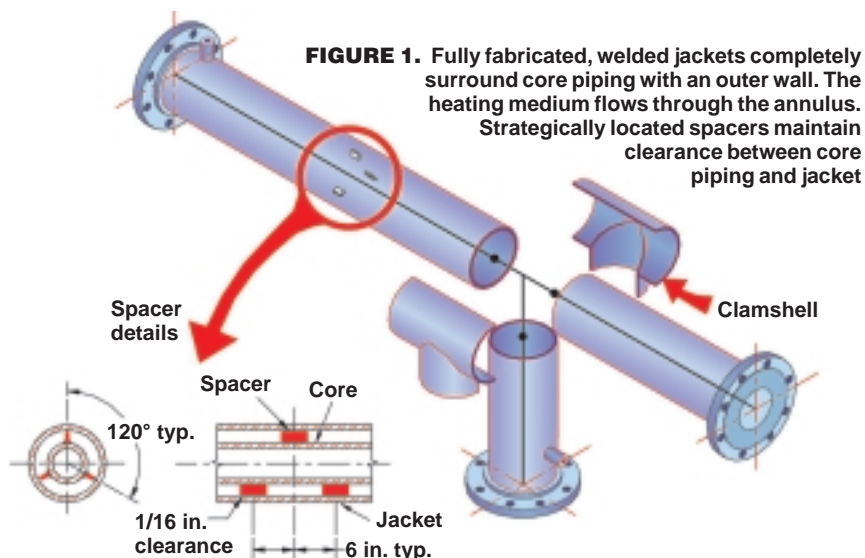

FIGURE 1. Fully fabricated, welded jackets completely surround core piping with an outer wall. The heating medium flows through the annulus. Strategically located spacers maintain clearance between core piping and jacket

Challenging process situations

The importance of a thermal maintenance system varies according to the process. Situations that, either individually or in combination, make the thermal-maintenance task more challenging include the following:

- **Process temperatures above 200°F, or low ambient temperatures.** The greater the gap between process temperatures and ambient, the more difficult thermal maintenance becomes. For instance, precursors to polyesters and nylons are high-temperature process fluids, with melt temperatures well above 500°F.

An example of a low-ambient-temperature complication recently cropped up in a Canadian plant recovering sulfur from natural gas: the sulfur-stream process temperature of 252 to 266°F is not very high (nor narrow; see next paragraph), but the ambient temperature can drop to -40°F. Originally, straight runs of pipe at this plant were jacketed, but not the elbows. However, when the operation

was shut down or whenever a big freeze hit, it became necessary to heat the elbows with torches and, sometimes, to rod out the solidified sulfur. Properly jacketing the elbows dramatically reduced maintenance costs and unscheduled outages

- **A narrow temperature window.** When the minimum and maximum allowable stream temperatures are close together, uniform thermal maintenance is a must, with no hot spots or cold spots along nor across the pipe. Several polymer processes, for example, require holding the fluid temperature within less than $\pm 4^\circ\text{F}$. Examples of process streams below 200°F but posing difficult thermal maintenance because of a narrow temperature window are acrylic acid, dairy products, and many pharmaceuticals

- **Frequent temperature cycling.** Batch processing is a prime instance in which the temperature of empty processing piping must be rapidly elevated to receive feedstocks. Quickly reaching and then maintaining steady-state temperature is critical to yield, throughput and profitability. For instance, one additive pilot plant that employs an array of interconnect-

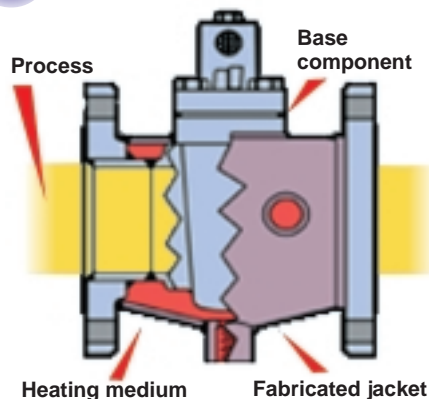

FIGURE 2. The welded-jacketing principle applies not only to piping but also to other components, including valves. Almost every system has design and construction principles that are particular to the application

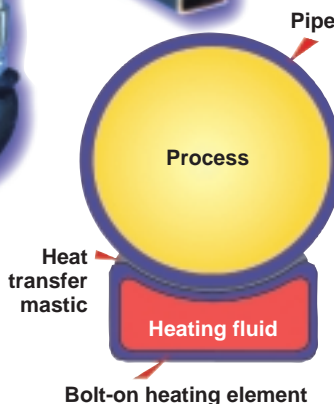
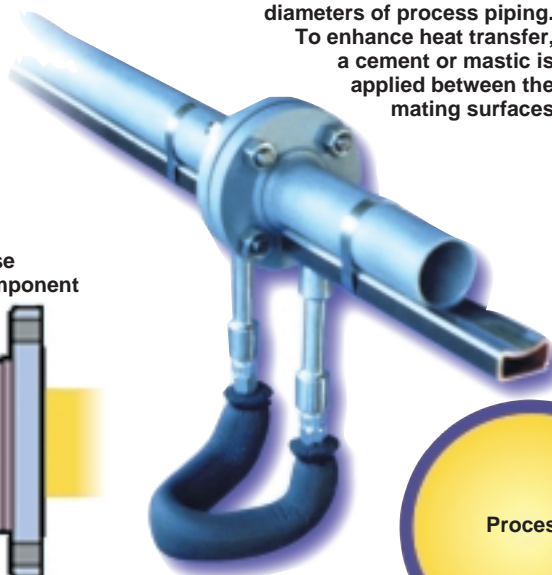

FIGURE 3. Bolt-on jackets are contoured tubes that mate with the outside diameters of process piping. To enhance heat transfer, a cement or mastic is applied between the mating surfaces

ing piping and instrumentation operates at 500°F and makes three or four batches per day

- **Stream pressures above 300 psig.** High pressure, whether in the process fluid or the heat-transfer fluid, complicates thermal maintenance because of the mechanical-strength requirements it poses. At one polymer plant with a nominally 320–350°F process stream passing through a relatively thin-walled, steam-jacketed pipe, operators accidentally pumped a 450°F reaction-intermediate fluid through the pipe instead. The higher temperature overpressured the steam to 400 psi, causing the core pipe to collapse

- **Chemically aggressive fluids.** For personnel safety and equipment protection, operations with certain classes of fluids demand absolute integrity of the thermal-maintenance system. Examples of such process streams include mineral acids and alkalies, liquid sodium, chlorinated organics, toluene diisocyanate and liquid phosphorus

- **Debottlenecking.** A debottlenecking project can inadvertently increase the need for effective thermal maintenance. For instance, one process plant

was experiencing condensation of some hydrocarbon components on the suction side of a gas compressor. After a debottlenecking project increased the operating pressure of the compressor, the device promptly became fouled by the condensate. The subsequent addition of a jacket for the compressor inlet piping has provided enough supplementary heat to prevent the problem

- **Unacceptable risks of cross-contamination.** It is, of course, never desirable for the process fluid and the heat-transfer fluid to become mixed. But some cases pose more of a risk, in safety or in economics, than others. For instance, cross-contamination with the heating medium in caprolactam operations, which operate within a relatively modest but tight temperature window, can be economically catastrophic. Maleic anhydride requires highly reliable jacketed piping because of similar sensitivity to the problem of cross-contamination

- **Piping density.** The presence of valves, pumps, meters and similar piping-system components can complicate the thermal maintenance problem, particularly in combination

with any of the above factors. The components as well as the straight pipe runs require thermal maintenance treatment. If left untreated, they become heat sinks

In contrast to the eight situations just summarized, if the process is unheated and the ambient climatic conditions are moderate, there is no major thermal-maintenance challenge. In such cases, properly specified and well-maintained insulation should forestall any impact from ambient cooling or heating. Be aware, however, that in practice, insulation does not always live up to this expectation.

Tracing is the simplest

Tracing is generally the least-expensive option for thermal maintenance. Tracing systems employ small-diameter tubing that is held in place along or around piping and components by strapping or other mechanical means. Sometimes a heat-transfer mastic

is used to enhance the contact between the tubing and the process part. The tubing carries a heat transfer fluid; often a water-glycol mixture, hot oil, or steam.*

Tube trace systems generally work well for simple freeze protection and other situations that do not involve the complications listed earlier. At higher temperatures or in frequent cycling, however, differential thermal expansion can cause sections of the tracing to warp or expand, pulling away from the pipe or components and impairing heat transfer. Furthermore, reapplying tube tracing effectively after system maintenance is often a challenge.

The fabrication option

Fabricated jacketing surrounds core piping spools (Figure 1) or components (Figure 2) with a welded outer wall. Its materials of construction range from carbon steel to high alloys. A heating medium, such as one of

*Electric tracing is also available. See, for instance, *CE*, September 1998, pp. 120ff and May 1995, pp. 104ff.

those mentioned above, flows through the annulus.

Most jacketed systems have design and construction details particular to the application. The details may range from unique flanges or fittings to special core taps and spacer designs. Figure 1 shows spacers separating the core pipe and the jacketing and keeping the core concentric within the jacket. Design and placement of the spacers can impact the integrity of the jacketed pipe system.

Many fabrication choices can likewise have an impact on the system performance. Accordingly, jacketed piping should be shop- (not field-) fabricated, so that the operations and inspections can be better controlled, code compliance facilitated, and proper testing carried out.

Bolt-on jacketing

As the name implies, bolt-on jacketing is bolted, clamped or banded into place, to fit closely over piping, valves, pumps, or other process equipment (often including tanks, other vessels, and filtration equipment, and even rail cars). Two independent pressure boundaries, the wall of the pipe or other component and the wall of the jacketing, isolate the process stream from the heating medium.

When applied to piping, such jacketing has a much higher heating capacity than tube tracing. Sections of hollow jackets contoured to mate with the piping are attached lengthwise either individually (Figure 3) or symmetrically, with a heat-transfer cement or mastic applied between the mating surfaces. Properly applied bolt-on pipe jacketing has enough stiffness and mechanical strength to avoid the warping problems that can befall tracing. High-quality bolt-on pipe (and vessel) jacketing is made from SA [Stress Analyzed] 178 Grade A boiler tubing, and pressure tested according to the relevant ASME codes. Steam, a glycol-water mixture or hot oil (liquid or vaporized) may be used as the heating medium.

For bolt-on jacketing of valves, instruments and pumps, the high-quality jackets are made of cast-to-fit aluminum pieces (Figure 4). Embedded in the casting is a fabricated pressure chamber through which the heating

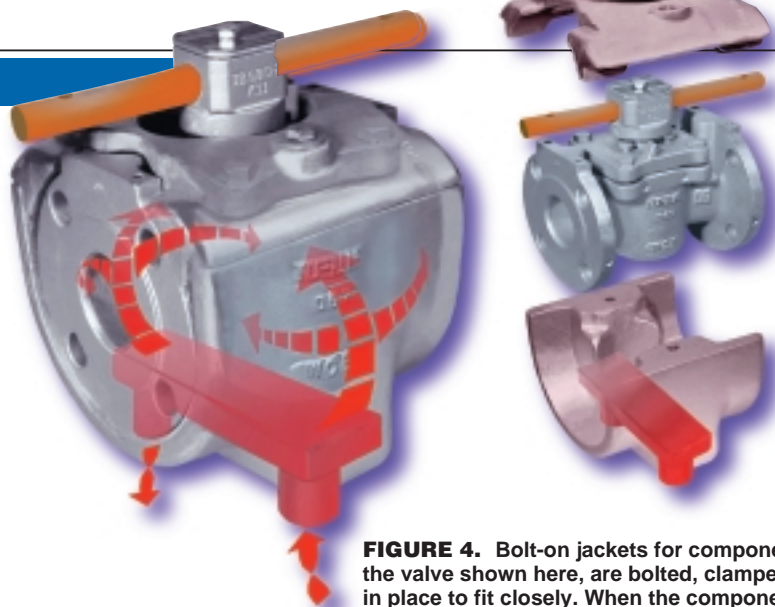

FIGURE 4. Bolt-on jackets for components, such as the valve shown here, are bolted, clamped or banded in place to fit closely. When the component must be replaced, the jacket can be removed, the new component installed, and the jacket bolted back on

medium flows. Electrically heated bolt-on jackets are also available.

Fabricated or bolted?

For cases in which tracing is inadequate, the decision between fabricated and bolt-on should center on process requirements, immediate and long term cost, cross-contamination risk tolerance, and piping density. The selection chart on p. 111 provides guidelines. Note, however, that there may well be exceptions. The final selection should be made with the assistance of a thermal maintenance specialist.

Fabricated systems transfer heat somewhat more efficiently than bolt-on jacketing, because the latter entail the double barrier between the heating medium and process stream. Therefore, fully fabricated systems may be preferable (on heat-transfer grounds) for process situations that include highly cyclical operation or require fast startups.

In most process applications, however, thermal maintenance is more important than quick startup. And even in cases where coming up to temperature quickly is important, the bottleneck to getting the plant back up and running quickly usually lies elsewhere. Whether the jacketing is fabricated (welded) or bolt-on, and whether it covers a run of piping or a valve or other piping component, the flow system protected by the jacketing is up to temperature before the rest of the process, particularly in the typical case where the process-side heat-transfer coefficients are limiting.

Fully fabricated systems are the

wiser jacketing strategy if the process operates within a very narrow temperature window (such as $\pm 3^{\circ}\text{F}$), at very near the degradation point, or above 600°F . For example, incomplete polymerization of a nylon 6 precursor can degrade entire batches if process temperatures are not maintained precisely within a very narrow window.

Some virtues of bolt-on

Life cycle ownership costs should also be considered. The bolt-on option is attractive in this regard, incurring total costs (including initial costs) about 25% lower than that of traditional fabricated jacketing.

A practical advantage is that the bolt-on jacketing is manufactured to fit any standard components (valves, for instance), and go on or off easily and quickly. Consequently, a plant can lower its component-inventory costs by buying and stocking standard, unjacketed replacement components, and installing or reinstalling the same jackets as needed. The situation becomes even more attractive if, instead, the local valve distributor keeps in stock all the standard valves likely to be needed — thus, the distributor is carrying the spares inventory. This is not possible with weld-on jacketed valves, which are not standardized.

As noted earlier, bolt-on systems provide more security against cross-contamination. This difference was recently illustrated when engineers designing a phthalic anhydride (PA) plant originally chose fabricated pipe for the thermal-maintenance system. When stress cracking caused a single

hidden failure of the core piping, PA mixed with the heating medium, contaminating the process stream.

The melting point of the contaminated process run was so high, the plant was not able to melt out the pipe. Hydroblasting of the pipe began, and a decision to switch to a bolt-on system quickly followed.

Another benefit of the bolt-on option is that, by eliminating the external pressure loading on the core piping, it allows a reduction of the wall thickness of the latter. In one case, core-pipe wall thickness was reduced from 1 in. to 3/16 in. This alone can represent a significant saving, especially on relatively large diameters and costly materials of construction.

There is considerable difference between design and fabrication of un-jacketed piping and of jacketed piping. Unjacketed piping is typically fabricated and installed beginning with the end connections. Properly fabricated jacketing, on the other hand, must be built from the middle, working towards the end connections, to allow for mandatory testing of the core piping before installation of the jacket. This work requires a thorough understanding of jacketing techniques and the behavior of the metallurgy used as the material of construction. From this standpoint, the relative simplicity of bolt-on jacketing is advantageous.

Finally, a contractual point may oc-

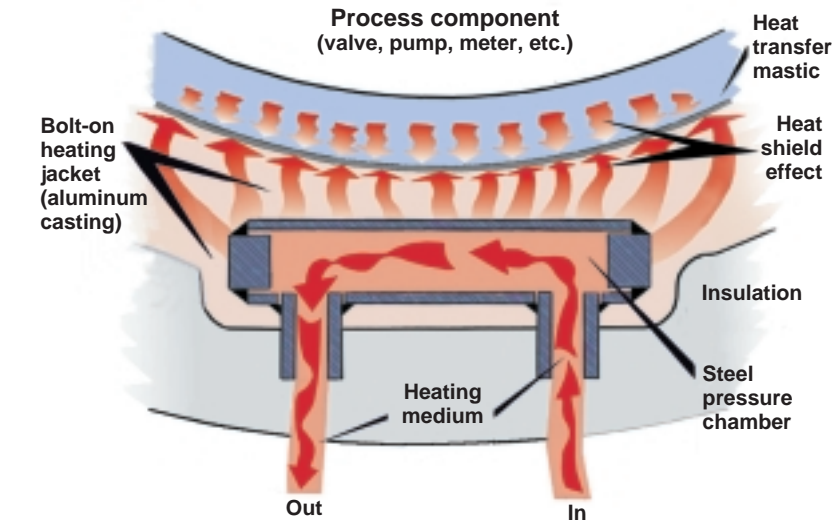

FIGURE 5. During the steady-state thermal maintenance of process equipment through the use of bolt-on jacketing, there is an essentially adiabatic barrier or heat shield in effect between the jacketing and the process component

asionally arise to affect the choice. Owners of technologies sometimes still require, as a condition for warranties, that licensees use fully jacketed (i.e., fabricated) systems. While this requirement may have once had some validity, the technology of bolt-on systems has meanwhile advanced greatly (with over 50,000 new applications in the past ten years).

In choosing between the two options, keep in mind that the best solution may be a hybrid of both. For example, on a vent line from sulfur storage, we recently recommended

fabricated jacketing for the first 50 ft, followed by bolt-on technology on the balance of the line. Process conditions required that the first 50 ft efficiently add heat to the process stream, with the balance operating simply as a thermal maintenance system.

Insist on these...

Regardless of the jacketing choice, thermal maintenance should not be regarded simply as a sideline of pipe contracting. For example, consider only those vendors that offer experience (documented by references from

SELECTION CHART FOR THERMAL MAINTENANCE						
	Effective Range of Process Temperatures	Handling Narrow Temperature Windows	Protecting Against Cross Contamination	Tolerating Dense Piping	Heat-transfer Efficiency	Comments
Tube tracing	<200°F	P	E	G	P	Good for "forgiving" processes: wide temperature windows and freeze protection; limited to moderate service temperatures.
Shop-fabricated jackets	200–800°F	E	G	G	E	Ideal for narrow temperature windows and cyclical and time-sensitive processes
Bolt-on component jackets	200–700°F	E	E	G	G	Double-wall concept protects against cross-contamination. Very uniform temperatures, good heat transfer. Easy changeout of valves, pumps, other components
Bolt-on piping jackets	200–700°F	E	E	F	G	Double-wall protection. Clamped on either individually, or symmetrically around pipe. Very economical on large-diameter pipe runs

E = Excellent
G = Good
F = Average
P = Poor

NOTE: These values are for general information only, and not for final system selection. Consult a thermal-maintenance specialist. Cost indices are not listed above, because relative costs depend highly on variables that vary from project to project.

past jobs) in the installation of thermal maintenance systems for process plants similar to the one being contracted. The vendors should be in a position to provide both fabricated and bolt-on jacketing.

They should also be willing to provide design support, or a review of the customer's designs. Typical vendor evidence to demonstrate this capability might include analyses, from past projects, of pressure drops and of steady-state and transient mechanical stresses and heat transfer.

Difficult thermal-maintenance projects require shop fabrication. It is hard, for instance, to maintain high radiographic-test acceptance on field-welded jacketed piping. Instead of merely inquiring about shop-fabrication (and, for that matter radiographic-test) capability, consider also asking for a tour of a proposed vendor's shop.

The vendors considered should employ procedure manuals that guide

them in every step of the fabrication and inspection process. The specifications, tests and inspections should all be spelled out in writing.

In this connection, make sure that a would-be vendor employs welders who are individually qualified for every procedure. Weld-inspection procedures should also be in writing. Finally, vendors of fabricated jacketing

systems must be code-certified in accordance with ASME and applicable international standards. ■

Edited by Nicholas P. Chopey

Author



Henry P. Gaines, Jr., P.E., is Vice-President of Controls Southeast, Inc. (12201 Nations Ford Rd., Pineville, NC 28134; Phone: 704 588-3030; Fax: 704 588-3039; E-mail: gaineshp@csiheat.com);). He directs the firm's thermal-maintenance operations, including involvement with design, development and evaluation of its fully fabricated and bolt-on jacketing systems. Before joining the company in 1988, he was a process development engineer for Dow Chemical Co., responsible for the development and implementation of improvements in polymer technologies. He also worked with Midrex Corp. and U. S. Ecology Corp. A licensed professional engineer, he holds a B.S.M.E. from Clemson University.



Our Bolt-On Heating Jackets Mean Smooth Sailing for The M/V Sulphur Enterprise



For four rigorous years at sea, the world's largest sulphur handler, Freeport McMoRan, Inc., has depended on our Bolt-On Heating System to transport more than 5 million tons of molten sulphur aboard the M/V Sulphur Enterprise. Over 6300 ft. of ControTrace, and 30 ControHeat jackets have maintained process temperature on the piping, valves and fittings without even one maintenance problem. The choice was easy. Our Bolt-On system eliminates the

chance for cross contamination without sacrificing thermal performance. And if that's not enough, ControHeat and ControTrace were able to save more than 25% in

investment costs versus traditional jacketed pipe and fabricated valve jackets.

We'd like to show you why our Bolt-On Heating System is emerging as the preferred technology for many heated processes. Please call us at 704-588-3030 or email us at sales@csiheat.com.

ENGINEERED SOLUTIONS FOR HEATED PROCESSES



POST OFFICE BOX 7500

CHARLOTTE, NORTH CAROLINA 28241

TELEPHONE: 704.588.3030

FACSIMILE: 704.588.3039

email: sales@csiheat.com

web: www.csiheat.com